

IRB 2600 Industrial Robot

The IRB 2600 is the second model in the sharp generation range with enhanced and new capabilities. It is a compact robot with a high payload capacity. The design has been optimized for targeted applications like arc welding, material handling and machine tending. The IRB 2600 is available in three variants, with options for floor, wall, shelf, tilted or inverted mounting configurations.

Sharp accuracy

With the best accuracy in its class, the IRB 2600 can help you increase output with higher process speeds and lower scrap rates, resulting in improved productivity. This is particularly useful in process applications, such as arc welding. The high accuracy is achieved by use of the patented TrueMove™ motion control software.

Short cycle times

Thanks to the compact and optimized design resulting in a low weight, the IRB 2600 can cut the cycle times of the industry benchmark by up to 25 %. The patented QuickMove™ motion control software ensures that the maximum acceleration achievable is highest in its class, together with high maximum speeds. The benefit is increased production capacity and high productivity.

Large working range

The combination of large working range and flexible mounting makes it possible to reach machines to be served without interfering with auxiliary equipment. By optimising the robot placement, you'll benefit from higher productivity. Flexible mounting is also very useful when you are simulating the best position for your application.



Compact design

The IRB 2600 has the same small foot print as IRB 4600. With the IRB 2600 you can create your production cell with reduced floorspace by placing the robot closer to the served machines. The foot size makes it easier for the lower arm to reach straight downwards.

Best protection available

ABB has the most comprehensive protection program for industrial robots on the market. The IRB 2600 has IP67 as standard and FoundryPlus 2 as option.

IRB 2600

Main applications

Machine tending, material handling, arc welding, cutting, dispensing, assembly, palletizing and packing, measuring

Specification

Variants	Reach	Payload	Armload
IRB 2600-12/1.65	1.65	12	15
IRB 2600-20/1.65	1.65	20	10
IRB2600-12/1.85	1.85	12	10
Number of axes	6+3 external (up to 36 with MultiMove)		
Protection	Standard IP67; optional FoundryPlus 2		
Mounting	Floor, wall, shelf, tilted, inverted		
IRC5 Controller variants	Single cabinet, Dual cabinet		

Physical

Dimensions robot base:	676 x 511
Robot height: IRB 2600-12/1.65 and IRB 2600-20/1.65	1382 mm
Robot height: IRB 2600-12/1.85	1582 mm
Robot weight:	272 to 284 kg

Performance (according to ISO 9283)

	Arm 1.65	Arm 1.85
Position repeatability (RP)	0.04 mm	0.04 mm
Path repeatability (RT)	0.13 mm	0.16 mm

Movement

Axis movements	Working range	Maximum speed
Axis 1	+ 180° to -180°	175 °/s
Axis 2	+ 155° to - 95°	175 °/s
Axis 3	+ 75° to - 180°	175 °/s
Axis 4	+ 400° to - 400°	360 °/s
Axis 5	+ 120° to -120°	360 °/s
Axis 6	+ 400° to - 400°	500 °/s

Electrical connections

Supply voltage	200-600 V, 50-60 Hz
----------------	---------------------

Environment

Ambient temperature for mechanical unit:

During operation	+ 5°C (41°F) to + 45°C (113°F)
During transportation and storage	- 25°C (- 13°F) to + 55°C (131°F)
For short periods (max 24h)	up to + 70°C (158°F)
Relative humidity	Max. 95% at constant temperature
Safety	Double circuits with supervisions, emergency stops and safety functions, 3-position enable device

Emission	EMC/EMI shielded
----------	------------------

Data and dimensions may be changed without notice

Working range

IRB 2600-12/1.65

IRB 2600-20/1.65

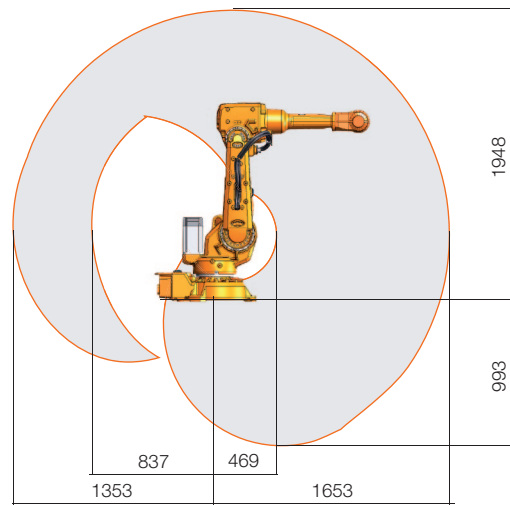

IRB 2600-12/1.85

