

Controlled by
DX100

The MOTOMAN ES165D-series are versatile, high-speed 6-axis robots offering superior performance in material handling, machine tending and press tending.

The ES165D/ES165D-100 offers a large work envelope and a high moment of inertia ratings. Fast axial speeds and acceleration reduce cycle times and increase production output.

The compact, slim design allows the robot to reach into confined spaces, improving system productivity.



Key benefits

- Fast, flexible and powerful
- Compact design allows maximum performance using minimal floor space
- High payload (165 kg/100 kg)
- Large working range (2,651 mm/3,010 mm)

MOTOMAN ES165D, ES165D-100

Spot welding, general purpose and handling

 **YASKAWA**

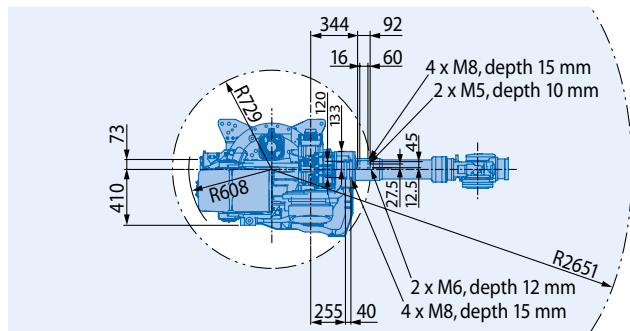
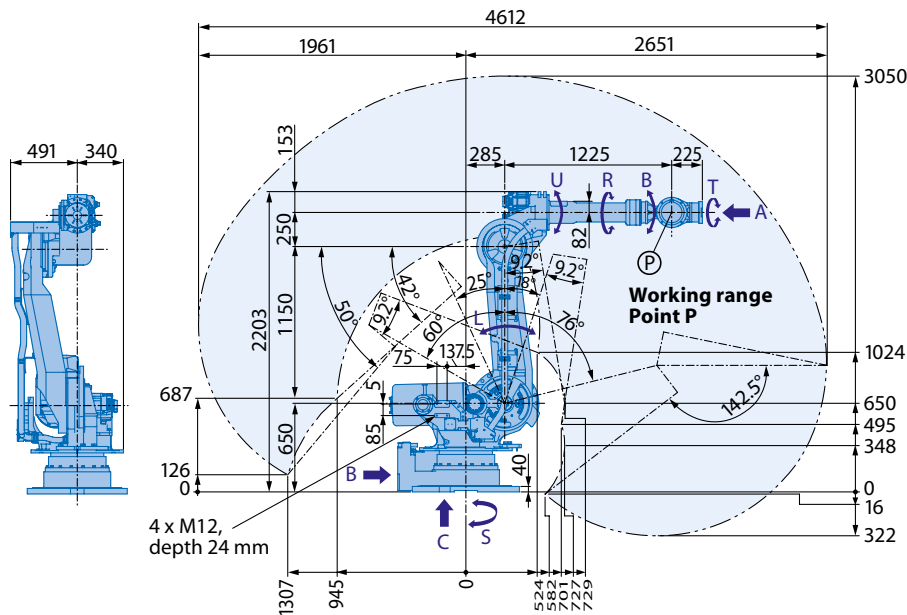

Allowable wrist load

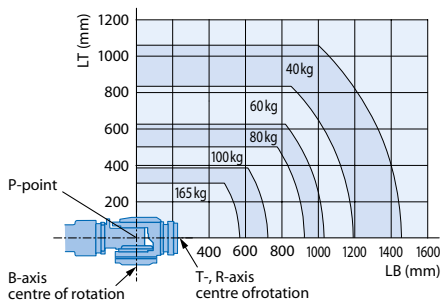

View A

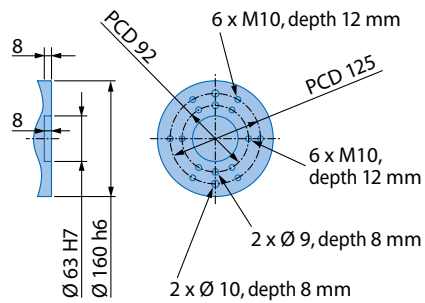

View B

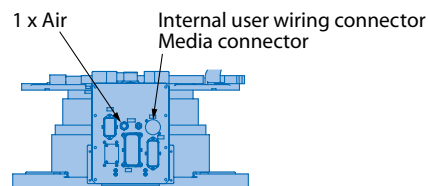

View C

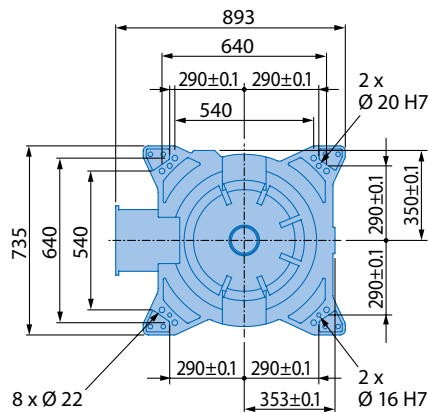

Mounting option: Floor

All dimensions in mm | Technical data may be subject to change without previous notice | Please request detailed drawings at robotics@yaskawa.eu.com – YR-ES0165D-B00, G-09-2014, A-No. 150285

Specifications ES165D

Axes	Maximum motion range [°]	Maximum speed [°/sec.]	Allowable moment [Nm]	Allowable moment of inertia [kg · m ²]	Controlled axes	
S	±180	110	–	–	Max. payload [kg]	6
L	+76/–60	110	–	–	Repeat. pos. accuracy [mm]	165
U	+230/–142.5	110	–	–	Max. working range [mm]	±0.2
R	±360	175	921	85	Temperature [°C]	R = 2651
B	±130	150	921	85	Humidity [%]	0 to +45
T	±360	240	490	45	Weight [kg]	20 – 80
					Power supply, average [KVA]	1100
						5

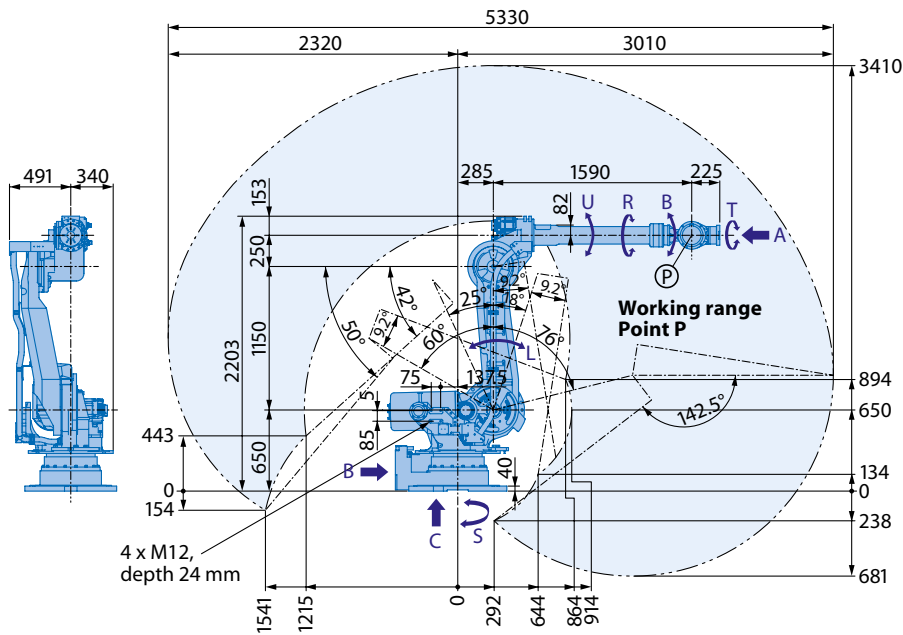

View A

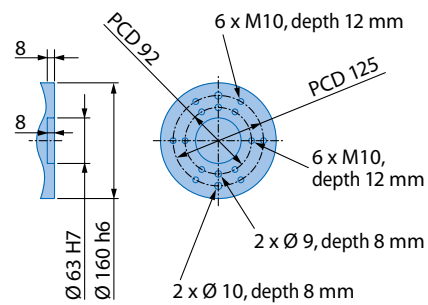

View B

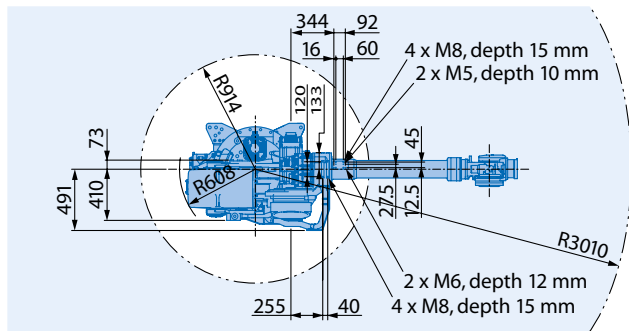
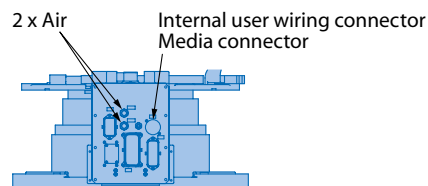

View C

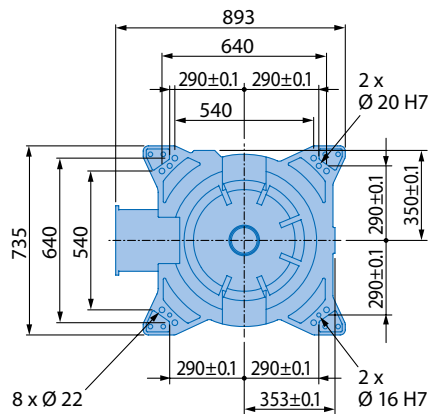

Mounting option: Floor

Allowable wrist load

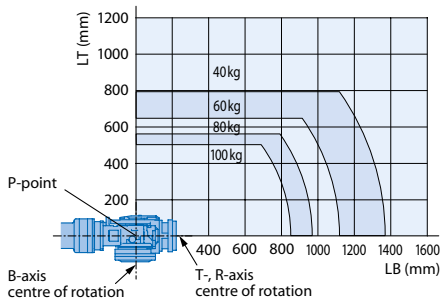

All dimensions in mm | Technical data may be subject to change without previous notice | Please request detailed drawings at robotics@yaskawa.eu.com – YR-E50165D-B10, G-09-2014, A-No. 150285

Specifications ES165D-100

Axes	Maximum motion range [°]	Maximum speed [°/sec.]	Allowable moment [Nm]	Allowable moment of inertia [kg · m ²]	Controlled axes	6
S	±180	110	–	–	Max. payload [kg]	100
L	+76/–60	110	–	–	Repeat. pos. accuracy [mm]	±0.2
U	+230/–142.5	110	–	–	Max. working range [mm]	R = 3010
R	±360	175	833	75	Temperature [°C]	0 to +45
B	±130	150	833	75	Humidity [%]	20 – 80
T	±360	240	490	25	Weight [kg]	1120
					Power supply, average [KVA]	5

YASKAWA
Headquarters
YASKAWA Europe GmbH
Robotics Division
Yaskawastraße 1
D-85391 Allershausen
Tel. +49 (0) 8166/90-0
Fax +49 (0) 8166/90-103

**YASKAWA academy and
sales office Frankfurt**
YASKAWA Europe GmbH
Robotics Division
Hauptstraße 185
D-65760 Eschborn
Tel. +49 (0) 6196/77725-0
Fax +49 (0) 6196/77725-39

YASKAWA Group

A YASKAWA Austria
Schwechat/Wien +43(0)1-707-9324-15

CZ YASKAWA Czech s.r.o.
Rudná u Prahy +420-257-941-718

E YASKAWA Ibérica, S.L.
Gavà/Barcelona +34-93-6303478

F YASKAWA France SARL
Saint-Aignan-de-Grand-Lieu
+33-2-40131919

FIN YASKAWA Finland Oy
Turku +358-(0)-403000600

GB YASKAWA UK Ltd.
Banbury +44-1295-272755

I YASKAWA Italia s.r.l.
Torino +39-011-9005833

IL YASKAWA Europe Technology Ltd.
Rosh Ha'ayin +972-3-9004114

NL YASKAWA Benelux B.V.
EB Son +31-40-2895500

RUS YASKAWA Nordic AB
Moskva +46-480-417-800

SE YASKAWA Nordic AB
Torsås +46-480-417-800

SI YASKAWA Slovenia
Ribnica +386-1-8372-410

TR YASKAWA Turkey Elektrik Ticaret Ltd. Sti.
İstanbul +90-216-5273450

ZA YASKAWA Southern Africa (PTY) Ltd
Johannesburg +27-11-6083182

Distributors

BG Kammarton Bulgaria Ltd.
Sofia +359-02-926-6060

CH Messer Eutectic Castolin Switzerland S.A.
Dällikon +41-44-847-17-17

DK Robotcenter Danmark
Losning +45 7022 2477

EE RKR Seadmed OÜ
Tallinn/Estonia +372-68-35-235

GR Gizelis Robotics
Nea Kifissia +30-2106251455

H Flexman Robotics Kft
Budapest +36-30-9510065

LT Profibus UAB
Panevezys +370-45-518575

N Optimove as
Lierstranda +47-32240600

PL Integrator RHC Sp. z o.o.
Torun +48-56-6519710

PT ROBOPLAN Lda
Aveiro +351-234 943 900

RO Sam Robotics srl
Timisoara +40-720-279-866

RO MPL Automation S.R.L.
Satu Mare +40 (0) 261 750 741



www.yaskawa.eu.com
robotics@yaskawa.eu.com

Technical data may be subject to change without previous notice.