

YASKAWA

MOTOMAN MPL300 II

Palletising with the MPL-series

The versatile and powerful 4-axis MOTOMAN MPL300 II robot provides high performance in box palletising, case palletising and many further logistical tasks for end-of-line or distribution center automation. Its extensive vertical reach of 3024 mm combined with 3159 mm horizontal reach enables high palletising loads. Internally

routed airlines and cables from base to end-of-arm tool maximize system reliability.

The MPL300 II is driven by the high-performance DX200 controller which is available with the optional Category 3 Functional Safety Unit (FSU), providing a variety of new safety functions.



KEY BENEFITS

- Compact, flexible and powerful
- High acceleration and speed:
Up to 1200 cycles/min., Suitable for box palletising
- High Payload: 300 kg
- Large motion range:
 - 2624 mm square reach (on pallet 1300 x 1300 mm)
 - 2363 mm stack height (on pallet 1600 x 1600 mm)
- Maximum reliability, internally routed airlines and cables
- Internally routed fieldbus connection to T-axis/tool
- Enhanced Safety Functions for DX200 Functional Safety Controller (FSU)
- Protection class IP54/67

Controlled by
DX200

MOTOMAN MPL300 II

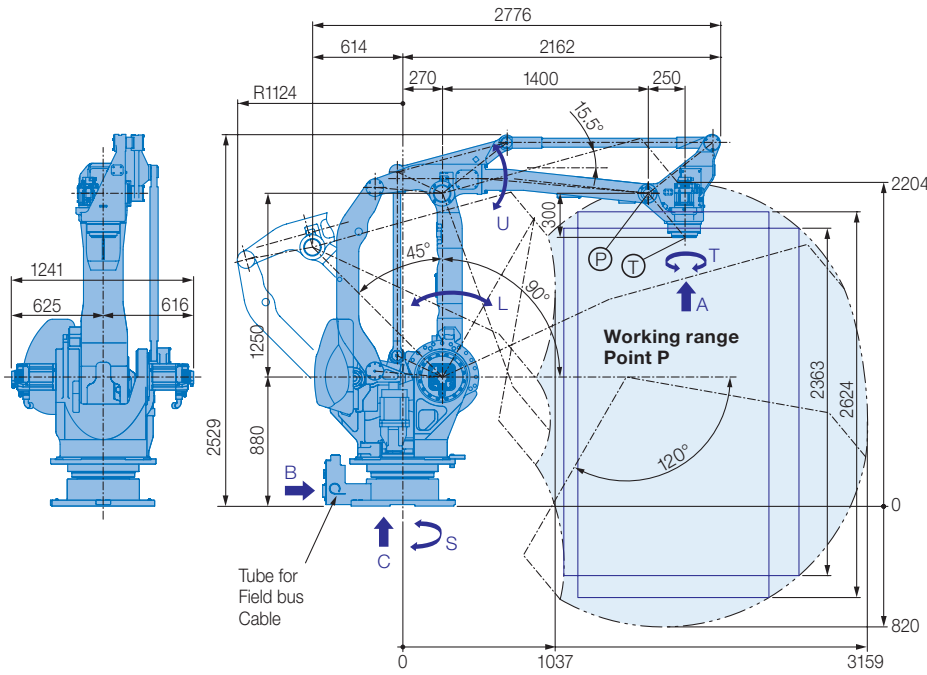

View A

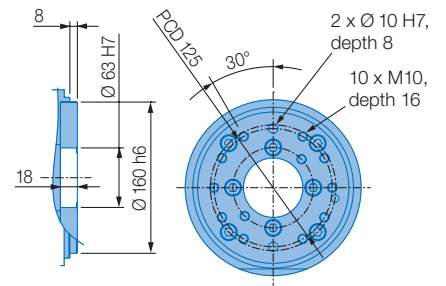

View B

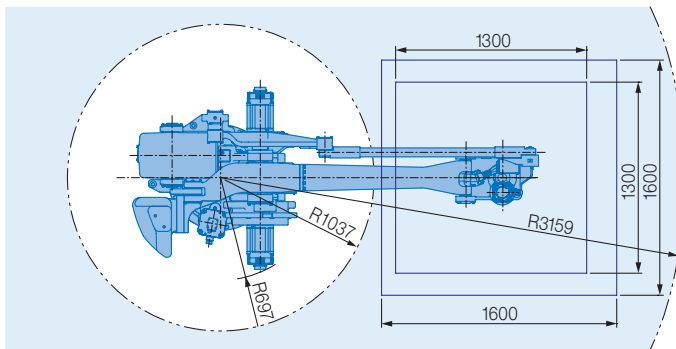
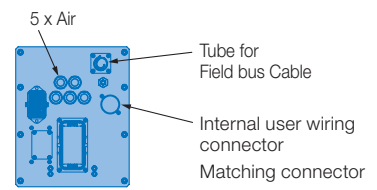

View C

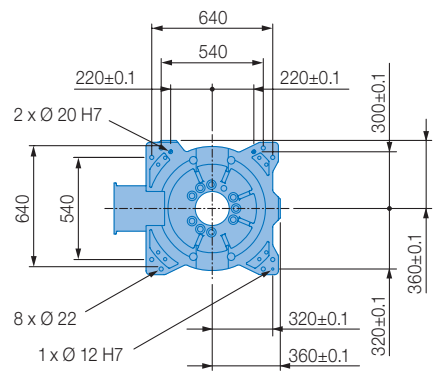

Mounting option: Floor

Allowable wrist load

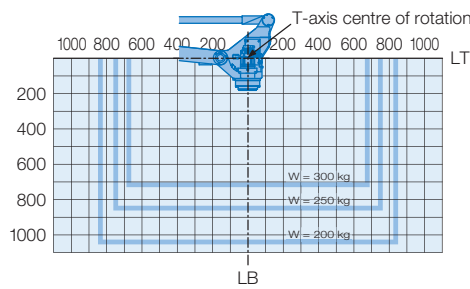

All dimensions in mm | Technical data may be subject to change without previous notice | Please request detailed drawings at robotics@yaskawa.eu.com - YR-MPL0300-J00, A-05-2015, A-No. 170968



Specifications MPL300 II

Axes	Maximum motion range [°]	Maximum speed [°/sec.]	Allowable moment [Nm]	Allowable moment of inertia [kg · m ²]	Controlled axes	
					Max. payload [kg]	
S	±180	90	-	-	Repeat. pos. accuracy [mm]	±0.5
L	+90/-45	100	-	-	Max. working range [mm]	R = 3159
U	+15.5/-120	110	-	-	Temperature [°C]	0 to +45
R	-	-	-	-	Humidity [%]	20 - 80
B	-	-	-	-	Weight [kg]	1820
T	±360	195	-	140	Power supply, average [KVA]	9.5

YASKAWA

robotics@yaskawa.eu.com
www.yaskawa.eu.com

YASKAWA Headquarters

YASKAWA Europe GmbH · Robotics Division
Yaskawastraße 1 · D-85391 Allershausen
Tel. +49 (0) 8166/90-0 · Fax +49 (0) 8166/90-103

YASKAWA academy and sales office Frankfurt

YASKAWA Europe GmbH · Robotics Division
Hauptstraße 185 · D-65760 Eschborn
Tel. +49 (0) 6196/77725-0 · Fax +49 (0) 6196/77725-39